



**Model OT-PLC604-2P/POE**

**4-Channel Ethernet Extender**

**Product User Manual**



[www.ourten.com](http://www.ourten.com)

**OT-PLC604-2P/POE 4-Channel Ethernet Extender** is 4-channel high-speed Ethernet Transmitter. It can simultaneously transmit 4 channels Ethernet over any 2-wire cable, such as Cat5, coaxial cable, telephone line, power line and so on. The Max transmission distance can reach 600m.

This product supports 1 PoE output and 3 non PoE output for different end-points, and needs to be used together with other Receivers. It can greatly simplify the project cabling, applied to expand network system and transmit long distance network device signals.

## Features

- ◆ Max transmission distance can reach 600m
- ◆ Full duplex 10/100Mbps
- ◆ Built-in switch function, greatly simplify installation
- ◆ Plug and play, transparent transmission, no adjustment and no need to change the upper software
- ◆ Power boost technology, support one PoE output

## Technical Parameter

Category		Description
<b>Power</b>	Available Voltage Range	12VDC±10%; 2A
	Power Consumption	≤3W / PC
	PoE Output	15.4W / af
<b>Transmission / Rate</b>	Standard Compliance	IEEE1901, IEEE802.3
	Up Down Agreement	CSMA/CA
	Bandwidth	Full duplex 10/100Mbps
	Encryption	128-bit AES Encryption
<b>Physical Characteristic</b>	Dimensions (L × W × H)	120mm×104mm×28mm
	Material	Aluminum
	Net Weight	260g/PC
<b>Operating Environment</b>	Working Temperature	-20°C~60°C
	Working Humidity	< 95% Non-condensation

# Installation Instructions

## Definition of Transmitter & Receiver; Terminal device & Remote device:

**Receiver & Transmitter:** Ethernet Extender Unit connected to the computer is Receiver by default. Ethernet Extender Unit connected to the camera is Transmitter by default.

**Terminal device / Remote device:** Terminal device generally refers to the direction of computer / machine room, and remote device generally refers to the direction of camera.

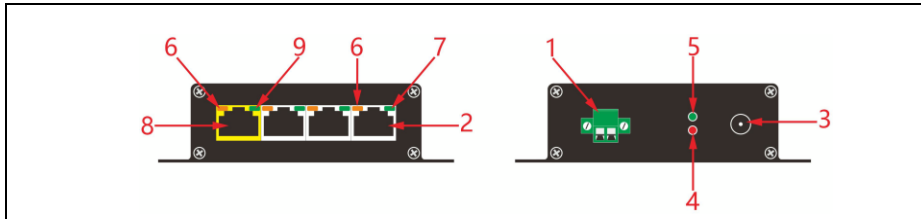

Step	Installation Instruction
1	2-Wire Terminal (1)
2	RJ45 Terminal (2)
3	Power Port (3)
4	Power indicator is always on (4)
5	Line status indicator is always on (5)
6	Data exchange status indicator is always flashing (6)
7	Always off (7)
8	PoE output port (8)
9	PoE signal detection indicator light is always on when PoE power supply output (9)

## Dimension

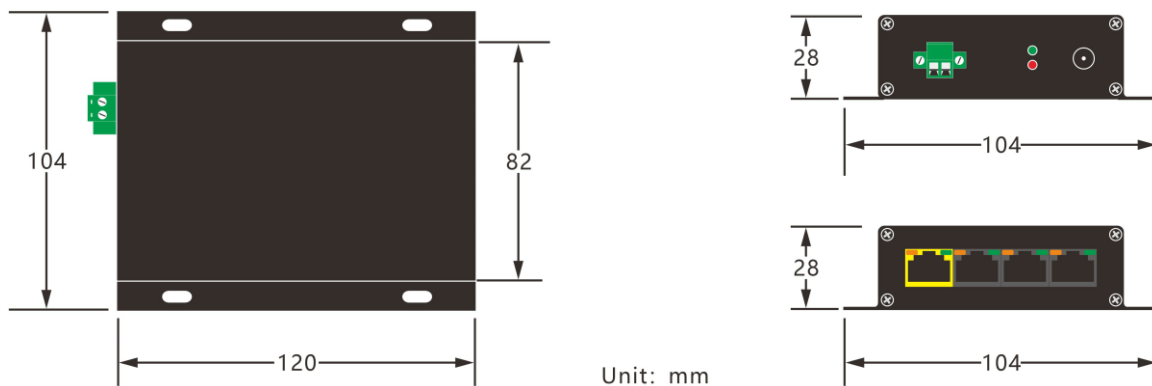

**Note: Dimension error value  $\pm 1$  mm**

## Installation Diagram

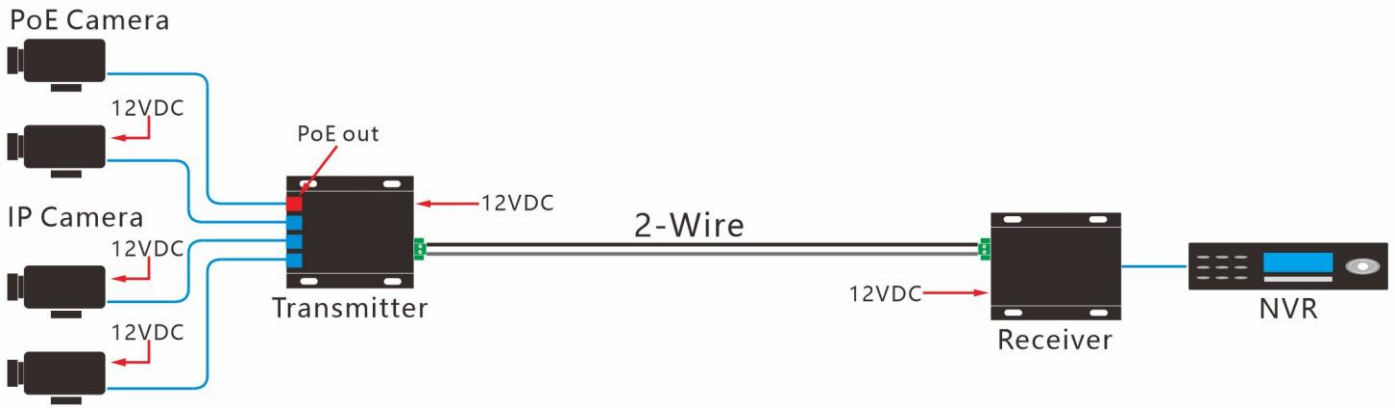

## Troubleshooting Method

### 1. When direct connection by network cable is normal, the lag time is large after connecting Ethernet Extender.

(1) Check 2-wire connection is correct or wrong. In the case of the wrong connection, the signal can be transmitted but the lag is very large.

### 2. After a period of using Ethernet Extender, the Ethernet signal has packet loss or disconnection.

- (1) Check the power adaptor status, if find they are aged or damaged, please replace it.
- (2) Check all the cable connections, if find any loose cable or short circuit, please solve it.

### 3. The screen is frozen, and the Ping packet is normal.

- (1) Ethernet Extender is transparent transmission. Check whether the version and setting of IP Camera are correct or not.
- (2) Check whether the throughput of network switch is enough or not. Please directly connect the computer to check the status.
- (3) Confirm if all the IP surveillance devices belong to the same brand or not, whether they support onvif, and then check their compatibility, do the test of reducing video stream.
- (4) If working environment temperature of Ethernet Extender is too high, firstly cut off the power supply. If confirm the devices are overheated, please adopt temperature decrease measures.

### 4. When multiple receiver units are placed together for use, they can't communicate or have significant network latency.

- (1) Install the receivers with a distance of at least 2 meters or place them separately in metal equipment boxes to avoid signal crosstalk.
- (2) Do the grouping for Ethernet Extenders by software. The grouping software is provided by us, please contact us timely.

## 5. The front-end PoE Powered Device abnormal operation

(1) Check if the power consumption of the front-end PoE powered device meets the 802.3af standard, and if the power consumption of PoE powered device exceeds the max effective PoE power output, the front-end PoE powered device can't work normally.

(2) Check the current size of the power adapter and replace it with a 12VDC/ 2A or higher current power adapter.

## Use Tips

When you use OT-PLC604-2P/POE, please follow the below tips as a reference, in order to reduce the fault in the process of using and the inspection work.

1. Signal transmission cable must be the copper cable. Other material cables will cause the decrease of signal transmission quality and distance.
2. Long distance cable connection must be formal connection methods, such as welding or using connectors.
3. Coaxial cable, twisted-pair cable, telephone line and power line all can be used to transmit network data signal in projects. A variety of cables arbitrary mixed connection also can reduce the quality of signal.
4. Please choose matching power supply **(12VDC/2A)**.
5. If need to transmit power at the same time, you should install power filter in the front of each device to make sure signal stability.
6. There is no waterproof design for this product, please make sure it is used in dry environment.
7. If device fails, do not disassemble or repair it by yourself. Please contact us timely.



Shaoxing Ourten Electronics Co., Ltd.

#1 Liando U Valley, No. 1999 Wuxing West Road, Shangyu, Zhejiang, China

Tel: +86-21-5888 9980 (+86-575-8213 7256); Fax: +86-575-8212 7256

Email: [sales@ourten.com](mailto:sales@ourten.com)

[www.ourten.com](http://www.ourten.com)

Thank you for choosing Ourten!